

The Beacon™ Series Waist-High Optical Turnstiles

Stainless Cabinet & Top • Interior Application

BE800-X

The Beacon™ Series is our line of barrier-free pedestrian control devices. Using a non-restrictive method to control traffic flow, these “optical” units are ideally suited for office personnel entrances where the majority of the people enter using an ID card. It allows for rapid pedestrian advancement and barrier free ADA access, while preventing “tail-gating” by those without credentials.

The BE800-X features a stainless cabinet and top, and will integrate with all standard access control equipment.



BE800-X

We're the #1 Choice of Top Architects, Security Pros and Engineers

For two decades, Controlled Access has been the globally trusted name in pedestrian control equipment. Made in Ohio and shipped worldwide, we are the first choice of leading architects, facility managers, security consultants and engineers. Whether your project requires high security full-height turnstiles, waist-high units, or matching ADA accessible gates, Controlled Access is the secure choice. And, we're experienced in access control systems, from card readers to biometric scanning, to give you the power to control access.



CA CONTROLLED ACCESS, INC.

The Leader in Pedestrian Access Control

1636 West 130th Street | Brunswick, Ohio 44212 | Ph: 330.273.6185 | Fax: 330.273.4468 | Toll-Free Ph: 800.942.0829 | Toll-Free Fax: 800.942.0828

E-mail: sales@controlledaccess.com | www.controlledaccess.com

The Beacon™ Series Waist-High Optical Turnstiles

BE800-X

Stainless Cabinet & Top • Interior Application

Applications:

This interior application optical unit is ideally suited for indoor office personnel entrances where the majority of people enter using an ID card.

Product Overview:

Our optical turnstile lanes operate with through beam type sensors to provide accurate monitoring of lane status. To this end, each lane requires a primary cabinet (receivers & logic controller) and secondary cabinet (transmitters). Hybrid cabinets (primary on one side and secondary on the other) are also available to allow multiple lanes per array of cabinets.

Each lane has two main zones comprised of a series of sensors to grant alarm-free passage or detect unauthorized access and tail-gating in either direction of travel.

In addition, crawl-detection sensors exist in the lower section of each cabinet to give additional security. In facilities where excessive low to the ground traffic is frequent, such as gyms with members dragging rolling bags, this feature can be disabled if desired.

Design & Construction:

- Designed for reliable operation with aesthetics in mind
- Bollard construction is of 304 stainless steel
- Dark tinted tempered glass provides a sleek appearance while concealing inner components
- Cabinet dimensions:
27-1/4" long x 39" high x 8-5/8" wide

Product Features:

- Optical sensors provide for passage for up to 30 people/minute
- Powerful through beam sensors which exceed sensing distance to ensure proper functionality
- Tri-color indicator lights for lane status
- Optical sensors to prevent unauthorized "crawling" thru lane
- Can be configured for controlled passage in one or both directions, with free or no passage in the other via settings on the logic controller
- Alarm condition provides audible tone as well as solid state output for integration into other systems

Installation:

- Dual-axis sensor alignment with visible target to ensure a simplified and reliable installation
- Nearly universal integration to any number of access control systems
- Low voltage (24VDC) requirements to secondary cabinet reduce conduit requirements
- Flexibility in passage widths:
from 22" to 38"

Warranty:

Units are warranted against defects in materials and workmanship for a period of one year from date of delivery. See warranty information for specific details.

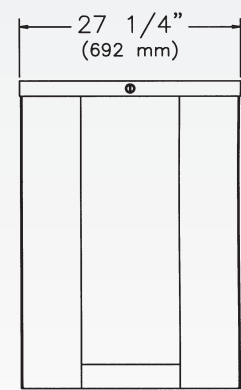
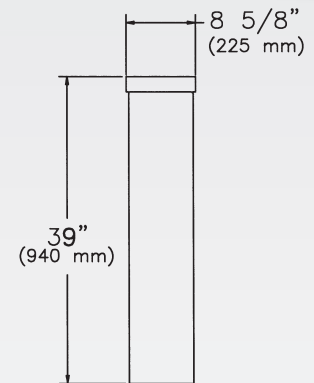

Dimensions are approximate.

Electrical Specifications:

Input Voltage: 100-240 VAC
Operating Voltage: 24 VDC
Operating Current: 15W per lane
Direction Inputs: Contact Closure
(Normally Open, Dry)

Standards and Codes:

Austenitic stainless steel:
ASTM A240, A249, A276
Stainless steel fasteners:
ASTM A-320
American Welding Society (AWS)
Standard D 1.1



Controlled Access, Inc. is
a registered ISO 9001:2008
company