

The Brute™ Series Waist-High

BR5500-P

Portable | Interior & Exterior Application

The Brute™ Series units operate reliably with high traffic volume areas where cost is an important consideration.

Heavy 7-gauge carbon steel cabinets can be interfaced with optional LCD counters, card readers, push button, and wireless remotes. Standard powder coat colors are shown below. Custom colors are available and can be quoted upon request.

Our matching tripod style unit is the BR5500-S. We also offer two ADA compliant handicap gates with this series (BR5000-ADA and BR5000-ADA-P; portable)



We're the #1 Choice of Top Architects, Security Pros and Engineers

For more than 30 years, Controlled Access has been the globally trusted name in pedestrian control equipment. Made in Ohio and shipped worldwide, we are the first choice of leading architects, facility managers, security consultants, and engineers. Whether your project requires high security full-height turnstiles, waist high units, or matching ADA accessible gates, Controlled Access is the secure choice. We're experienced in access control systems, from card readers to biometric scanning, to give you the power to control access.



Standard powder coating color selections:

Additional colors available and can be quoted upon request.

Geiger Black II 60% Gloss (aka Vulcan Black)	RAL 9003 Signal White	RAL 1013 Oyster White	RAL 9007 Grey Aluminum	RAL 5023 Distant Blue	RAL 5010 Gentian Blue	RAL 6002 Leaf Green	RAL 8028 Terra Brown

Controlled Access, Inc.
Turnstiles and ADA Gates

1535 Industrial Parkway South, Brunswick, OH 44212

PH: 330.273.6185 | Fax: 330.273.4468
Toll-Free Ph: 800.942.0829 | Toll-Free Fax: 800.942.0828

E-mail: sales@controlledaccess.com
www.controlledaccess.com

The Brute™ Series Waist-High

BR5500-P

Portable | Interior & Exterior Application

Applications:

This portable turnstile is made for years of reliable service (and offers many options) where cost is an important consideration. It is ideal for public venues such as convention halls, fairs, amusement parks and cafeterias.

Product Features:

Materials and Finishes:

- **Lid:** Our signature 304 stainless steel / No. 4 satin finish
- **Cabinet:** Your choice of 8 designer powder coat colors to match any décor. Black is standard. Custom RAL colors can be quoted.

Design & Construction:

- Designed for secure and reliable operation with aesthetics in mind
- Cabinet is constructed with rigid (7 gauge) carbon steel
- Cover is constructed with (16 gauge) 304 stainless steel, No. 4 satin finish
- Arm assembly constructed with 1 5/16" (33.4mm) diameter, (12 gauge) stainless steel
- Hub 4 1/2" (114.3mm) o.d. also made from stainless steel

Dimensions:

- **Height:** 37" (939.8mm)
- **Width:** 32.750" (831.8mm)
- **Depth:** 20.125" (511.2mm)
- **Passage:** 18.5" (469.9mm)

* Dimensions are subject to change without notice



Optional battery back-up available

Operation Features

6500 Series Control Head:

- Auto-indexing (self-centering) with adjustable hydraulic shock suppression
- Hardened tool steel locking bars, cam and roller assemblies
- Permanently lubricated bearings
- Your choice of manual or electronic control on both directions
- Nearly universal integration to any number of access control systems
- Your choice on each electronic direction of locking or unlocking on power failure

Options:

- Daylight visible indicator lights
- Bi-directional key overrides
- 8 digit key resettable LCD counter with seven year lithium battery
- 12 Ah battery back-up system (2x 12VDC batteries) with 2 amp 24VDC charger with base cover
- Additional options available upon request

Warranty:

Units are warranted against defects in materials and workmanship for a period of one year from date of delivery. See warranty information for specific details.

Electrical Specifications:

Input Voltage: 100-240 VAC
Input Current: 1.3 - .55 A
Frequency: 50/60 Hz
Storage Temperature: -40 to 158°F
Operating Temperature: -4 to 131°F
Operating Voltage: 24VDC
Operating Current: 1.2 A (typical)

Standards and Codes:

Austenitic stainless steel:
ASTM A240, A249, A276
Hot rolled steel:
AISI C-1020, AISI C-1018
All fasteners provided meet IFI ANSI/
ASME Fastener Standards
American Welding Society (AWS)
Standard D 1.1



The 6500 Series Control Head is certified to conform to the following standards:
UL 294, UL 325, UL Subject 2593,
CAN/ULC S319 & CSA C22.2#247



Controlled Access, Inc. is certified by Advantage International Registrar to be an ISO 9001:2015 company

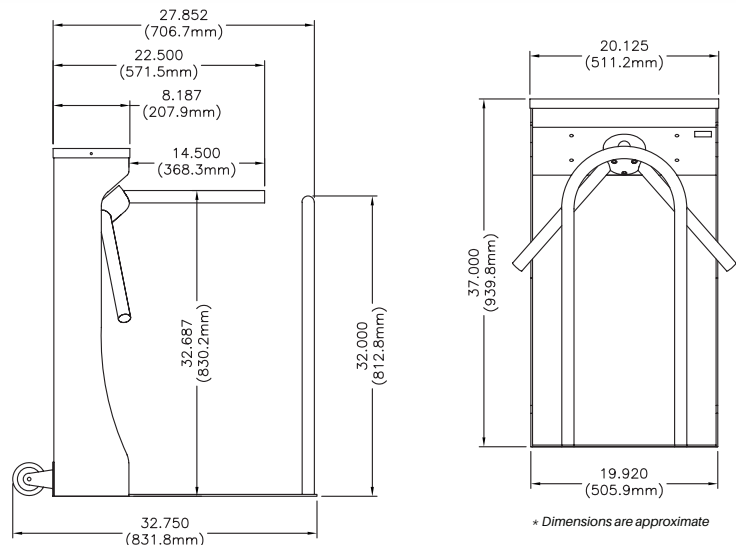

Controlled Access, Inc.
Turnstiles and ADA Gates

1535 Industrial Parkway South, Brunswick, OH 44212

PH: 330.273.6185 | Fax: 330.273.4468
Toll-Free Ph: 800.942.0829 | Toll-Free Fax: 800.942.0828
E-mail: sales@controlledaccess.com
www.controlledaccess.com