

# The Executive™ Series Waist-High

ADA Swing Gate with Round End | Interior Application

EX100-R-ADA



The Executive™ Series is our premier interior application unit. It is ideal for prestige settings such as banks, offices, embassies, and museums. This highly versatile line can take on any look. It features our signature 304 stainless steel/No. 4 satin finish with a solid surface top to match your design needs.

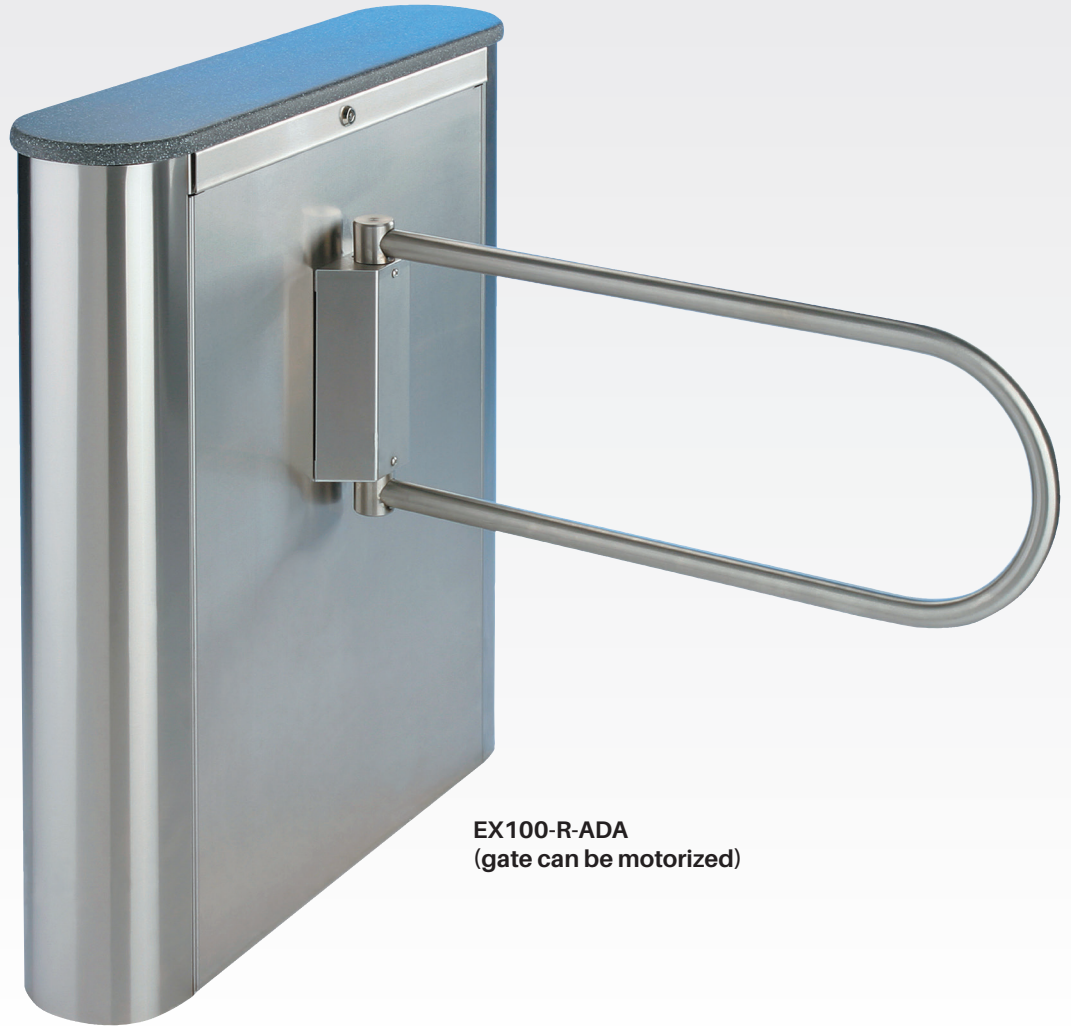

EX100-R-ADA  
(gate can be motorized)



Optional wood top upgrade  
shown with lights

## We're the #1 Choice of Top Architects, Security Pros and Engineers

For more than 30 years, Controlled Access has been the globally trusted name in pedestrian control equipment. Made in Ohio and shipped worldwide, we are the first choice of leading architects, facility managers, security consultants, and engineers. Whether your project requires high security full-height turnstiles, waist high units, or matching ADA accessible gates, Controlled Access is the secure choice. We're experienced in access control systems, from card readers to biometric scanning, to give you the power to control access.



### Standard top selections include:

Listed color selections are current (as of 2/6/23). Top selections are subject to availability.



**Controlled Access, Inc.**  
Turnstiles and ADA Gates

1535 Industrial Parkway South, Brunswick, OH 44212

PH: 330.273.6185 | Fax: 330.273.4468  
Toll-Free Ph: 800.942.0829 | Toll-Free Fax: 800.942.0828  
E-mail: [sales@controlledaccess.com](mailto:sales@controlledaccess.com)  
[www.controlledaccess.com](http://www.controlledaccess.com)

# The Executive™ Series Waist-High

EX100-R-ADA

## ADA Swing Gate with Round End | Interior Application



### Applications:

This ADA compliant unit is the matched partner to the EX100-R interior application unit. It is designed for controlling the orderly flow of foot traffic in prestige settings such as banks, offices, embassies and museums.

### Product Features:

#### Materials and Finishes:

- **Lid:** A solid surface (or wood) top with your choice of 12 standard colors selections. Custom colors and Corian® can be quoted
- **Cabinet:** Our signature 304 stainless steel/ No. 4 satin finish

### Design & Construction:

- Designed for secure and reliable operation with aesthetics in mind
- Cabinet constructed of 304 stainless steel/ No. 4 satin finish
- Arms constructed of 1-5/16" (33.4mm) diameter (12 gauge) stainless steel
- Triple strand chain drive with adjustable chain tensioners
- Minimal exposed hardware

### Dimensions:

- **Height:** 38.925" (988.7mm)
- **Width:** 47.250" (1200.1mm)
- **Depth:** 36.750" (933.4mm)
- **Passage Way:** 36" (914.4mm)

\* Dimensions are subject to change without notice



Our matching waist high turnstile (EX100-R) is available for the Executive Series.

### Operation Features

#### 6500 Series Control Head:

- Auto-indexing (self-centering) with adjustable hydraulic shock suppression
- Hardened tool steel locking bars, cam and roller assemblies
- Permanently lubricated bearings
- Your choice of manual or electronic control on both directions
- Nearly universal integration to any number of access control systems
- Your choice on each electronic direction of locking or unlocking on power failure

### Options:

- Bi-directional key overrides (fail open only)
- 8 digit key resettable LCD counter with seven year lithium battery
- ADA push to exit placard button
- Variable arm lengths (up to 40")
- Signage bracketry
- Variable speed self-opening motorized arm  
*\*comes with safety clutch to prevent injury*
- Daylight visible indicator lights
- Corian®, wooden or other alternate top choices outside of our standard selection
- **NEW!** Stainless steel round end tops now available
- Additional options available upon request

### Warranty:

Units are warranted against defects in materials and workmanship for a period of one year from date of delivery. See warranty information for specific details.

### Electrical Specifications:

Input Voltage: 100-240 VAC  
Input Current: 1.3 - .55 A  
Frequency: 50/60 Hz  
  
Storage Temperature: -40 to 158°F  
Operating Temperature: -4 to 131°F  
  
Operating Voltage: 24VDC  
Operating Current: 1.2 A (typical)

### Standards and Codes:

Austenitic stainless steel:  
ASTM A240, A249, A276  
  
Hot rolled steel:  
AISI C-1020, AISI C-1018  
  
All fasteners provided meet IFI ANSI/  
ASME Fastener Standards  
  
American Welding Society (AWS)  
Standard D 1.1



The 6500 Series Control Head is certified to conform to the following standards:  
UL 294, UL 325, UL Subject 2593,  
CAN/ULC S319 & CSA C22.2#247



Controlled Access, Inc. is certified by Advantage International Registrar to be an ISO 9001:2015 company

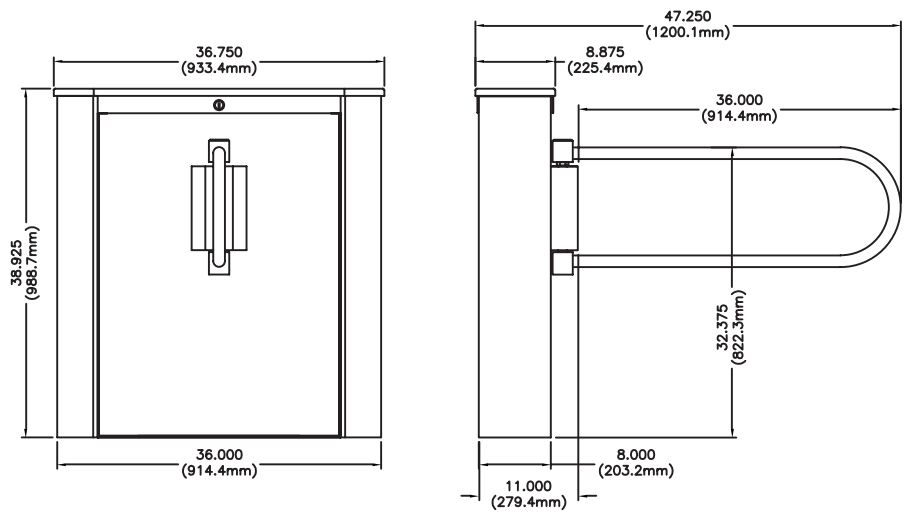

\* Dimensions are approximate

**Controlled Access, Inc.**  
Turnstiles and ADA Gates

1535 Industrial Parkway South, Brunswick, OH 44212

PH: 330.273.6185 | Fax: 330.273.4468  
Toll-Free Ph: 800.942.0829 | Toll-Free Fax: 800.942.0828  
E-mail: [sales@controlledaccess.com](mailto:sales@controlledaccess.com)  
[www.controlledaccess.com](http://www.controlledaccess.com)