

The Stadium FastPass™ Series Waist-High

Bolt Down | Interior & Exterior Application

FP500

FP500-C | FP500-T

The Stadium FastPass™ Series is made for years of reliable service in high traffic/volume applications like stadiums, convention centers, landmarks and military bases. Thousands are currently in use at leading pro-sports venues, amusement parks and high-profile attractions worldwide.

The cabinets are constructed of heavy 14-gauge, 300 series satin stainless steel and features our 6500 Series Control Head (with auto indexing and shock suppression technology). The cabinets can be interfaced with optional LCD counters, card readers, push button, and wireless remotes.

We offer a matching ADA compliant handicap gate with this series (FP500-ADA).



FP500



FP500-C (coin)



FP500-T (ticket box)

We're the #1 Choice of Top Architects, Security Pros and Engineers

For more than 30 years, Controlled Access has been the globally trusted name in pedestrian control equipment. Made in Ohio and shipped worldwide, we are the first choice of leading architects, facility managers, security consultants, and engineers. Whether your project requires high security full-height turnstiles, waist high units, or matching ADA accessible gates, Controlled Access is the secure choice. We're experienced in access control systems, from card readers to biometric scanning, to give you the power to control access.



CA Controlled Access, Inc.
Turnstiles and ADA Gates

1535 Industrial Parkway South, Brunswick, OH 44212

PH: 330.273.6185 | Fax: 330.273.4468
Toll-Free Ph: 800.942.0829 | Toll-Free Fax: 800.942.0828
E-mail: sales@controlledaccess.com
www.controlledaccess.com

The Stadium FastPass™ Series Waist-High

Bolt Down | Interior & Exterior Application

FP500

FP500-C | FP500-T

Applications:

This series is made for years of reliable service in high traffic/volume environments like stadiums, convention centers, amusement parks, landmarks and military bases.

Product Features:

Material:

- Our signature 304 stainless steel/ No. 4 satin finish

Design & Construction:

- Designed for secure and reliable operation with aesthetics in mind
- Cabinet constructed of 304 stainless steel/ No. 4 satin finish
- Arms constructed with 1 5/16" (33.4mm) diameter, (12 gauge) stainless steel
- Hub 4 1/2" (114.3mm) o.d. also made from stainless steel
- Minimal exposed hardware

Dimensions:

- **Height:** 38.062" (966.8mm)
- **Width (standard):** 23.218" (589.7mm)
- **Width (-C/-T):** 23.218" (589.7mm)
- **Depth (standard):** 27.437" (696.9mm)
- **Depth (-C/-T):** 33.437" (849.3mm)

* Dimensions are subject to change without notice

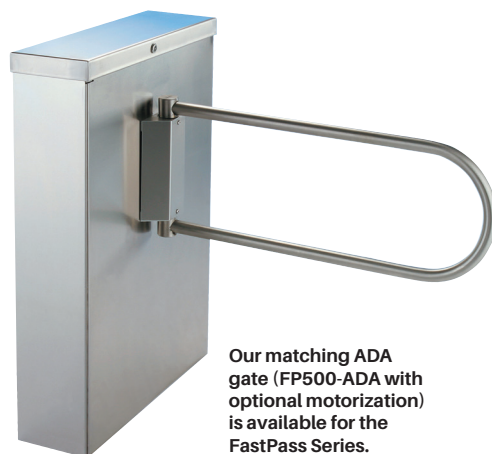

Our matching ADA gate (FP500-ADA with optional motorization) is available for the FastPass Series.

Operation Features

6500 Series Control Head:

- Auto-indexing (self-centering) with adjustable hydraulic shock suppression
- Hardened tool steel locking bars, cam and roller assemblies
- Permanently lubricated bearings
- Your choice of manual or electronic control on both directions
- Nearly universal integration to any number of access control systems
- Your choice on each electronic direction of locking or unlocking on power failure

Options:

- Daylight visible indicator lights
- Bi-directional key overrides
- 8 digit key resettable LCD counter with seven year lithium battery
- Coin/token acceptor
- Bill acceptor
- Ticket drop box
- Additional options available upon request

Warranty:

Units are warranted against defects in materials and workmanship for a period of one year from date of delivery. See warranty information for specific details.

Electrical Specifications:

Input Voltage: 100-240 VAC
Input Current: 1.3 - .55 A
Frequency: 50/60 Hz
Storage Temperature: -40 to 158°F
Operating Temperature: -4 to 131°F
Operating Voltage: 24VDC
Operating Current: 1.2 A (typical)

Standards and Codes:

Austenitic stainless steel:
ASTM A240, A249, A276
Hot rolled steel:
AISI C-1020, AISI C-1018
All fasteners provided meet IFI ANSI/
ASME Fastener Standards
American Welding Society (AWS)
Standard D 1.1



The 6500 Series Control Head is certified to conform to the following standards:
UL 294, UL 325, UL Subject 2593,
CAN/ULC S319 & CSA C22.2# 247



Controlled Access, Inc. is certified by Advantage International Registrar to be an ISO 9001:2015 company

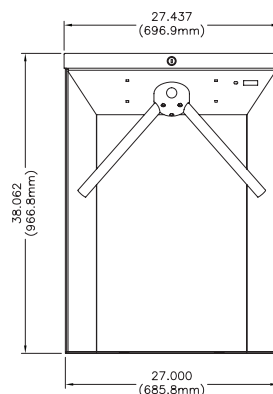

(FP500)

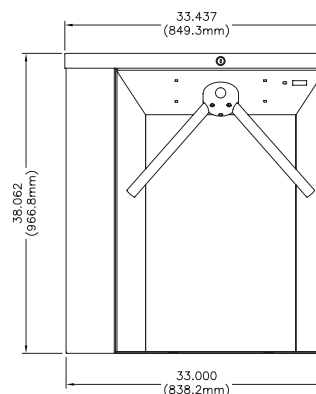

(FP500-C-T)

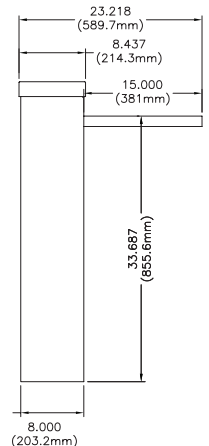

* Dimensions are approximate

Controlled Access, Inc.
Turnstiles and ADA Gates

1535 Industrial Parkway South, Brunswick, OH 44212

PH: 330.273.6185 | Fax: 330.273.4468
Toll-Free Ph: 800.942.0829 | Toll-Free Fax: 800.942.0828
E-mail: sales@controlledaccess.com
www.controlledaccess.com